

MA1002

Single Axis MEMS Capacitive Accelerometer



Main Features

- Range: $\pm 2g$, excellent bias stability: 0.03mg
- Output: differential output
- Single power supply: 4.75~5.25V
- Dynamic range: $\geq 100dB$, bandwidth (-3dB): 200Hz
- Low Noise: $\leq 2.5\mu grms/\sqrt{Hz}$, fully calibrated
- Embedded temp. sensor & precision reference voltage
- Extra small LCC20 package (9.0mm x 9.0mm)
- Wide operating temperature range: $-40\sim+125^{\circ}C$

MA1002 MEMS accelerometer is the best closed loop high performance capacitive accelerometer, it adopts high performance ASIC and MEMS sensor to build closed-loop system, it enjoys excellent performance with low noise, dynamic range, non linearity, repeatability, temperature drift and shock resistance.

MA1002 accelerometer also has the ability of built-in-self test, temperature sensor for compensation and built-in high precision reference voltage, which ensures MA1002 to be the top level of accelerometer around the world. Using tiny sealed LCC20 encapsulation (9*9mm), MA1002 has been widely used in Seismic Monitor, Inertial Navigation, Industrial Control, Platform Stabilization, Avionics, UAV systems, and Motion Control. MA1002 accelerometer's high reliability and excellent performance gains customers' high praise.

- ✓ 12-Step Quality Control, Super Reliability, More Functions
- ✓ Adopting Original Big Brand Component, High-class Material, Competitive Price

- ✓ Real Actual Precise after Calibration, Perfect Performance
- ✓ Successful Applications in Tens of Fields, More than 1000 Customers are Using

Typical Applications



Seismic Monitor



Railway Technology



Monitoring & Control

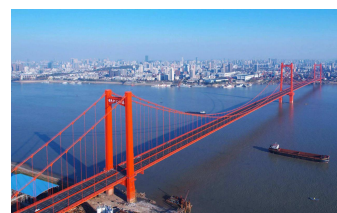

Structure Health Monitor

Super Reliability & Performance

www.SkyMEMS.com Mobile: +86 133 7203 8516
Skype: skymems

Copy Right Reserved © 2019 Nanjing Sky MEMS Technology co., Ltd.
Focus on MEMS Measurement & Control Technologies, Products include:

MEMS Acc	MEMS Gyro	IMU	Vertical Gyro	AHRS
INS	GNSS/INS	E-compass	Inclinometer	FOG

MA1002

Single Axis MEMS Capacitive Accelerometer

Technical Specifications

Technical Specs (Test condition: Vcc=5V, 25°C)

Parameter	Comments	Min	Typ.	Max	Unit
Accelerometer					
Range			±2		g
Non linearity	IEEE Norm , % of full scale		0.1	0.3	%
Frequency Response	±5% bandwidth	-	60	-	Hz
	±3dB bandwidth	-	200	-	Hz
Resonant frequency		-	1.4	-	kHz
Noise Spectral Density	In band [0.1Hz~100Hz]	-	12.5	-	μgrms
	@0.1Hz	-	4.4	-	μg/√Hz
	@1Hz	-	2.0	-	
	@10Hz	-	1.5	-	
	@100Hz	-	1.1	-	
Bias					
Zero Calibration		-40	-	+40	mg
Temperature coefficient		-0.2	-	0.2	mg/°C
Stability	1 hour, 1σ	0.01	0.03	0.08	mg
Repeatability		0.10	0.15	0.40	mg
Scale Factor					
Scale Factor		1782	1800	1818	mV/g
Temperature coefficient		75	95	120	ppm/°C
Stability	1σ	40	120	170	ppm
Repeatability		50	120	170	ppm
Axis misalignment					
Input Axis Misalignment (Kp,Ko)		-	-	10	mrad
Self Test					
Frequency	Square wave output	-	19	-	Hz
Duty cycle		-	50	-	%
Amplitude	Peak to peak	-	0.42	-	g
STEN Input Threshold Voltage	Active high	0.8	-	-	Vcc

MA1002

Single Axis MEMS Capacitive Accelerometer

Technical Specifications

Technical Specs (Continued)

Parameter	Comments	Min	Typ.	Max	Unit
Temperature Sensor					
Output Voltage	@25°C	-	2.5	-	V
Sensitivity		-	8.3	-	mV/°C
Output Current Load		-	-	20	uA
Output Capacitive Load		-	-	30	pF
Reset					
RSTN Input Threshold Voltage	Low level valid	-	-	0.2	Vcc
Power Supply (Vcc)					
Input Voltage		4.75	5	5.25	V
Running Current Consumption		-	5.4	-	mA
Startup Time	Turn on or RSTN pull-up	-	10	-	ms
Accelerometer Output					
Output Voltage	Full range differential output	-	±3.6	-	V
Resistance Load		10	-	-	kΩ
Capacitive Load		-	-	30	pF

MA1002

Single Axis MEMS Capacitive Accelerometer

Pins Definition

Pins Definition of MA1002

Pins No.	Pins Name	Definition	Description
1, 2, 3, 4, 5, 6, 8, 9, 10, 19, 20	GND	connect to ground	power ground
7	Vcc	power	5V power input
11	STEN	digital input	self test input, default inner drop down, seft test is valid when it is high level power
12	RSTN	digital input	external reset input, default inner pull up, low level reset is valid
13	PORN	digital output	power on reset output, the output is high when the power voltage is stable
14	OUTN	analog output	differential output negative
15	OUTP	analog output	differential output positive
16	TEMP	analog output	temperature sensor output
17	STDO	digital output	self test output synchronized signal
18	NC	-	no connection

Pins Figure

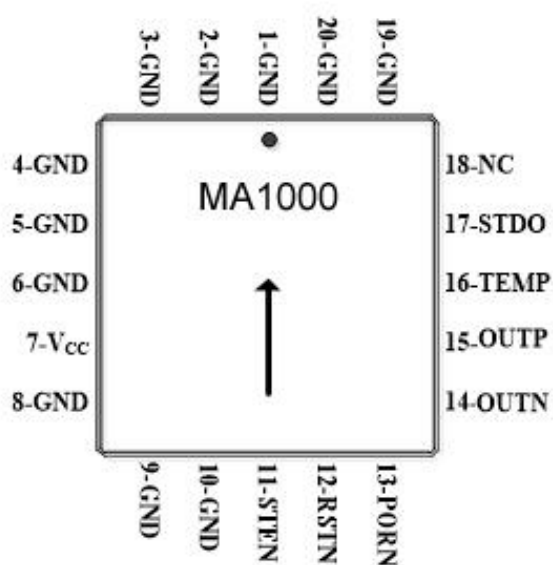

Pins Output of MA1002

Super Reliability & Performance

MA1002

Single Axis MEMS Capacitive Accelerometer

Absolute Max. Ratings

Absolute Maximum Ratings			
Parameter	Minimum	Maximum	Description
Power Supply	-0.3V	5.8V	
Pins' voltage	-0.3V	V _{cc} +0.3	
Working Temperature	-40°C	+125°C	
Storage Temperature	-55°C	+150°C	
Vibration Resistance	-	20g	random, [20, 2000Hz], X, Y, Z axis
Shock Resistance	-	6000g	one time, 0.15ms sine wave, ±X, ±Y, ±Z axis
ESD Level	-2kV	2kV	HBM mode

Remarks: the accelerometer that works long time in absolute maximum ratings may influence the reliability.

Handling Precautions

MA1002 accelerometer is encapsulated in a hermetic ceramic housing to protect the sensor from the ambient environment. However, poor handling of the product can induce damage to the hermetic seal (Glass frit) or to the ceramic package made of brittle material (alumina). It can also induce internal damage to the MEMS accelerometer that may not be visible and cause electrical failure or reliability issues. Handle the component with caution: shocks, such as dropping the accelerometer on hard surface, may damage the product.

The component is susceptible to damage due to electrostatic discharge (ESD). Therefore, suitable precautions shall be employed during all phases of manufacturing, testing, packaging, shipment and handling.

Accelerometer will be supplied in antistatic bag with ESD warning label and they should be left in this packaging until use. The following guidelines are recommended:

- Always manipulate the devices in an ESD-controlled environment
- Always store the devices in a shielded environment that protects against ESD damage (at minimum an ESD-safe tray and an antistatic bag)
- Always wear a wrist strap when handling the devices and use ESD-safe gloves

ESD caution



This product can be damaged by electrostatic discharge (ESD). Handle with appropriate precautions.

MA1002

Single Axis MEMS Capacitive Accelerometer

Self-test Function

MA1002 accelerometer has self test function. During self test, pull up STEN (pin 11) voltage into 5V. In self test mode, if the accelerometer works normally, self test output pin STDO and differential output pin OUTP/OUTN will output around 19Hz periodic square wave signal, see as following picture. In other mode,

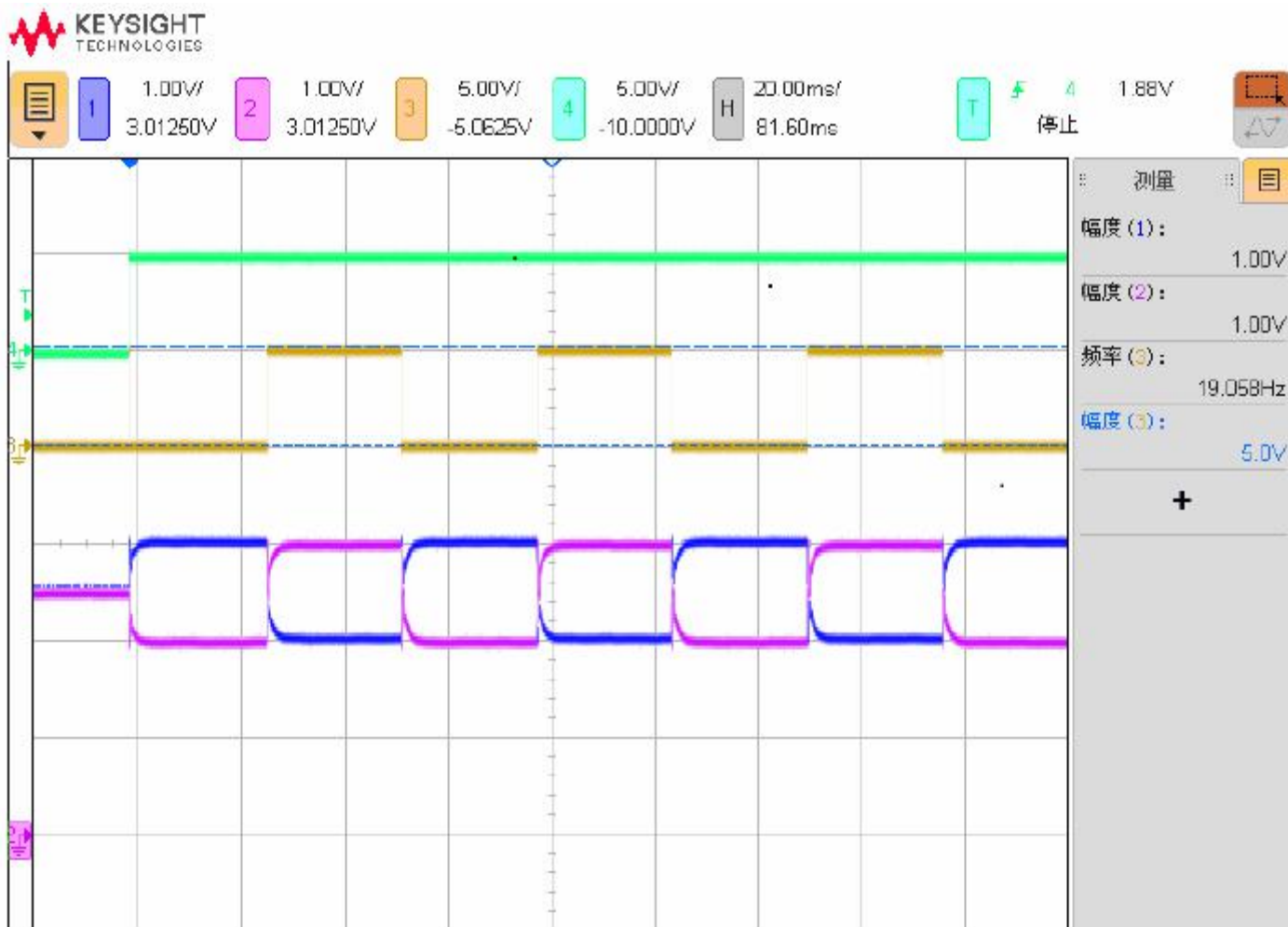

Channel 1: OUTP, Channel 2: OUTN, Channel 3: STDO, Channel 4: STEN

MA1002

Single Axis MEMS Capacitive Accelerometer

Reset Function

MA1002 accelerometer has reset function. During reset, pull down RSTN (pin 12). In reset mode, the accelerometer output (OUTP, OUTN): differential mode is 0, and common mode is 2.5V. After cancelling reset, the accelerometer output will enter stable working status after 4ms. the following picture is the output wave graph under reset mode (the accelerometer in the picture is in 1g status).

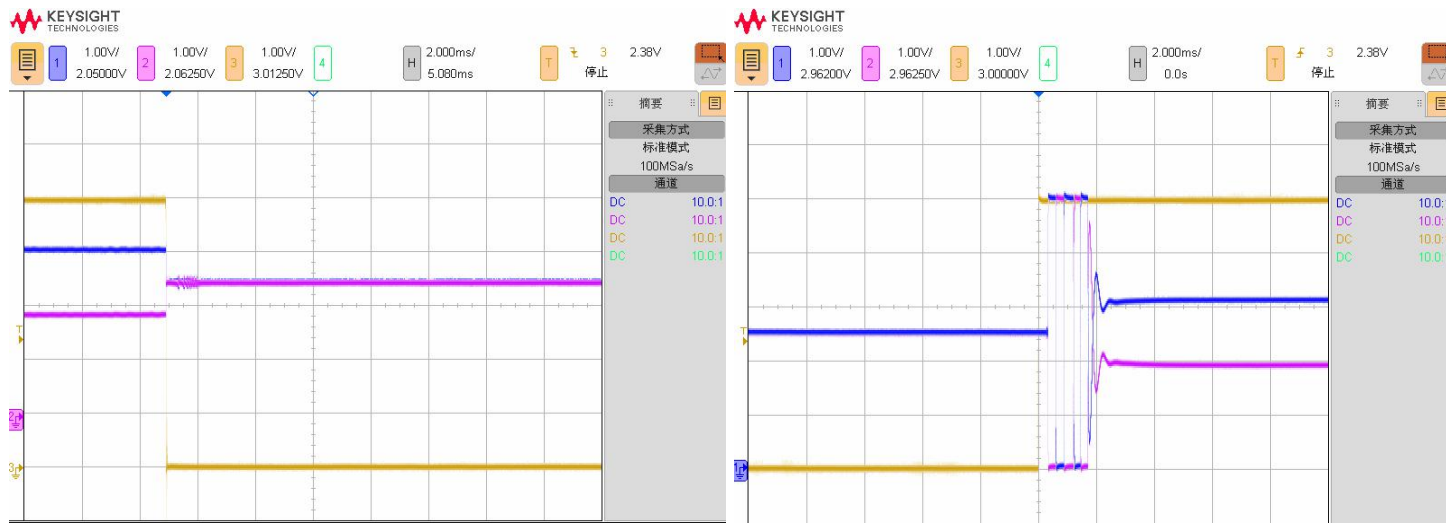

Channel 1: OUTP, Channel 2: OUTN, Channel 3: RSTN

MA1002

Single Axis MEMS Capacitive Accelerometer

Recommended Circuit

In order to obtain the best MA1002 accelerometer, please use MA1002 accelerometer according to the following application circuit.

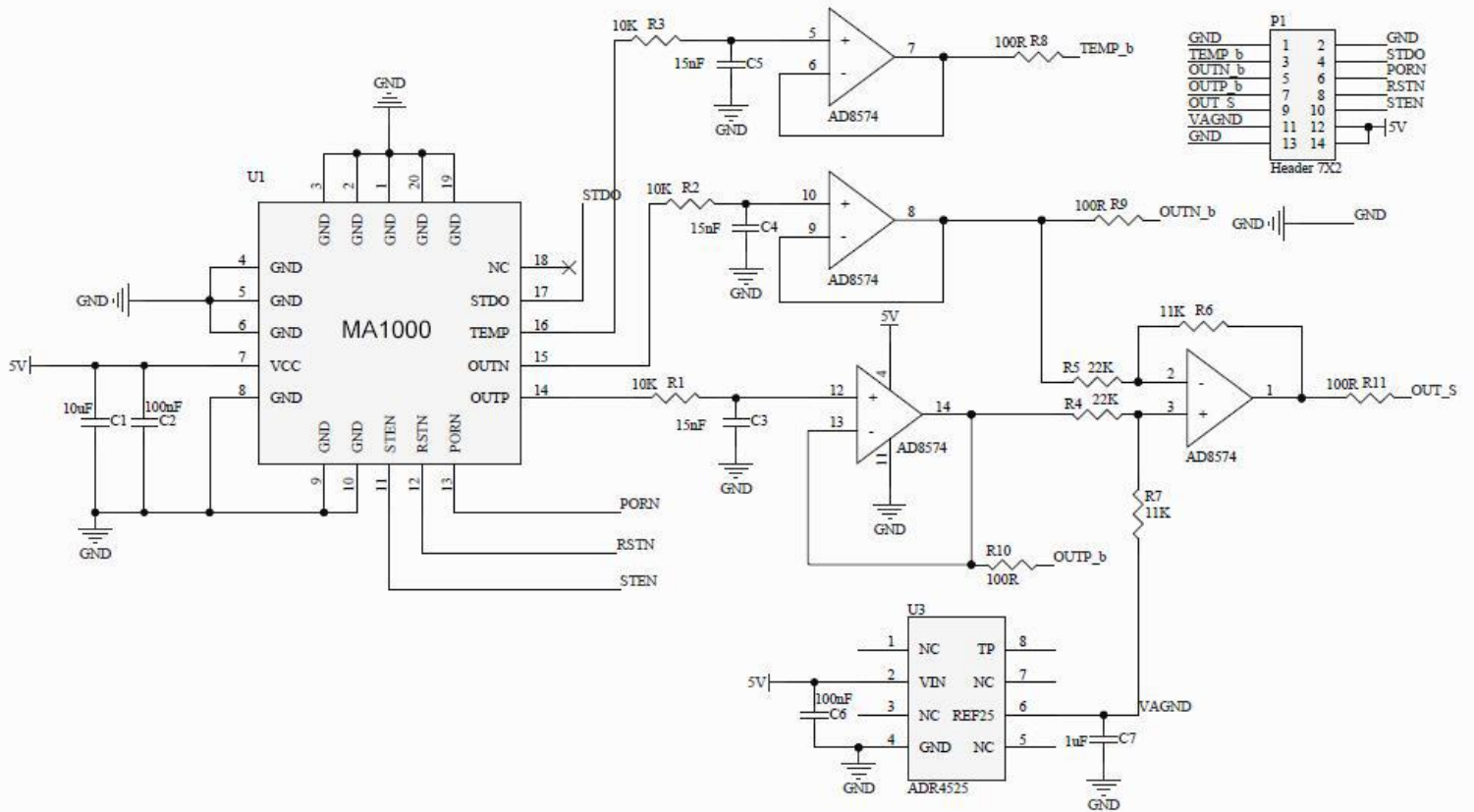

MA1002

Single Axis MEMS Capacitive Accelerometer

Soldering Method

MA1002 accelerometer is high precise MEMS accelerometer, in order to keep MA1002 excellent working performance and reliability, please pay attention during soldering: put the component in stable, don't vibrate it, and assure every pin to be soldered well, and make the component paralleled with the application circuit, and make the whole accelerometer bear averaged force.

MA1002 is suitable for Sn/Pb and Pb-Free soldering and ROHS compliant. the melting point can't be higher than 220°C

the recommended typical temperature profiles settings are as follows:

- Preheat--temperature: normal temperature~145°C, ramp-up of 1~2°C/second;
- Fusion--temperature: 145~165°C, duration: 100seconds;
- Peak--temperature: 220°C, duration: 45seconds;
- Cold--temperature: 220°C~normal temperature, ramp-down: natural temperature reduction;

In actual usage, the above parameters can be adjustable according to the selected solder material (the peak temperature can't exceed 220°C)

The cleaning process of electronic boards sometimes involves ultrasounds. This is strongly prohibited on our sensors. Ultrasonic cleaning will have a negative impact on silicon elements which generally causes damages.



**Forbidden
Ultrasonic
Cleaning**

Note: Ultrasonic cleaning is forbidden in order to avoid damage of the MEMS accelerometer

MA1002

Single Axis MEMS Capacitive Accelerometer

Dimension & Package

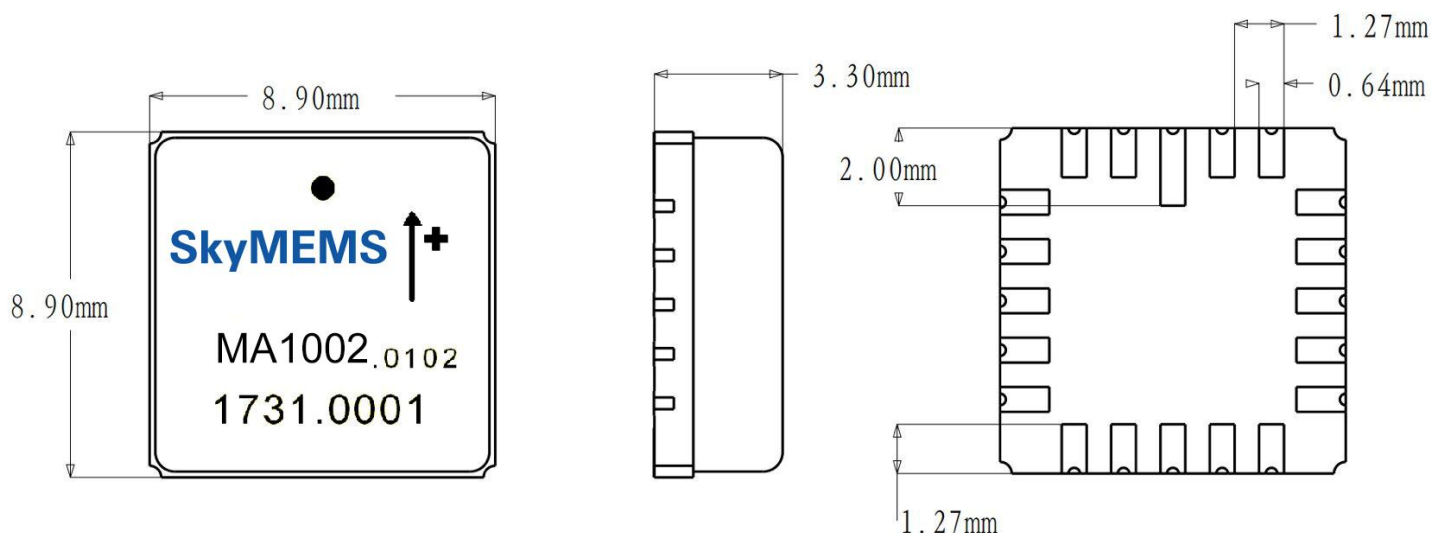

MA1002 Package

Parameter	Comments	Min	Typical	Max	Unit
Lead Finishing	Au plating	0.5	-	-	um
	Ni Plating	2	-	-	um
	W (tungsten)	16	-	-	um
Weight		0.63	0.639	0.645	grams
Size	X	8.95	9	9.07	mm
	Y	8.92	9.01	9.1	mm
	Z	3.3	3.38	3.45	mm
Packaging	LCC20 pin housing				
Proximity effect	The sensor is sensitive to external parasitic capacitance. Moving metallic objects with large mass or parasitic effect in close proximity of the accelerometer (mm range) must be avoided to ensure best product performances. A ground plane below the accelerometer is recommended as a shielding.				
Reference plane for axis alignment	LCC must be tightly fixed to the circuit board, using the bottom of the housing as the reference plane for axis alignment. Using the lid as reference plane or for assembly may affect specifications and product reliability (i.e. axis alignment and/or lid soldering integrity)				

MA1002

Single Axis MEMS Capacitive Accelerometer

Order Information

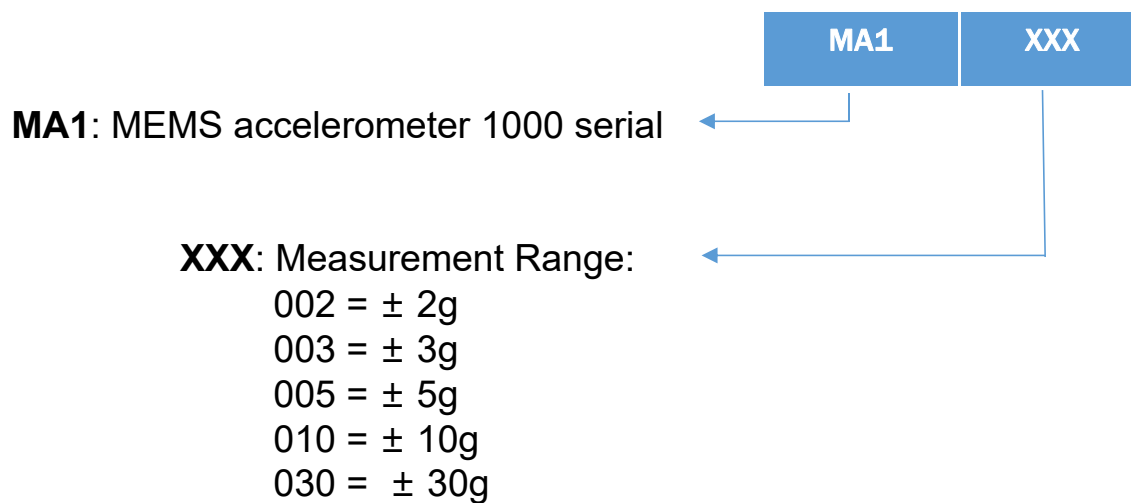

For example, MA1002 means that the accelerometer ± 2g range