

MAS3012

High Performance Triaxial MEMS Accelerometer Sensor

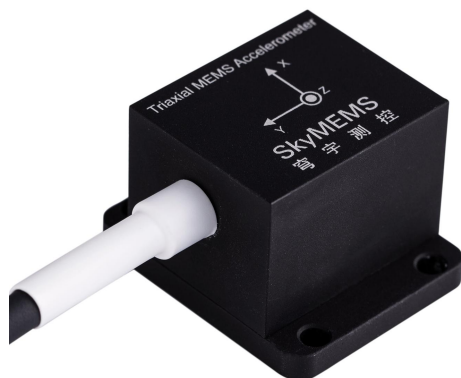

Main Features

- Closed Loop Structure MEMS Capacitive Accelerometer
- Range: $\pm 2g$, Excellent Bias Stability
- Dynamic Range: $\geq 110dB$,
- Bandwidth: $\geq 1KHz$ (Typical Value, -3dB)
- Low Noise: $\leq 1.0\mu grms/\sqrt{Hz}$
- Non-linearity: 0.1%FS (Full Range)
- Extremely Reliable in Harsh Environment
- Wide Operating Temperature Range: $-40\sim+85^{\circ}C$

MS3012 triaxial MEMS accelerometer sensor is one type of high performance vibration monitoring sensor base on MEMS technologies. It adopts 7~40V or $5V\pm 3\%$ power supply, integrate X-Y-Z trial axes and self test function, it adopts high performance accelerometer, the dynamic range can reach 110dB.

MS3012 accelerometer sensor has passed the strictest tests, it enjoys excellent performance in noise, dynamic range, non-linearity, repeatability, temperature drift, shock proof, etc. this product is an ideal option for seismic monitor, vibration monitoring, high speed train/metro train, test platform of vibration and shocking, structure health monitoring, etc.

- ✓ 12-Step Quality Control, Super Reliability, More Functions
- ✓ Adopting Original Big Brand Component, High-class Material, Competitive Price

- ✓ Real Actual Precise after Calibration, Perfect Performance
- ✓ Successful Applications in Tens of Fields, More than 1000 Customers are Using

Typical Applications



Seismic Monitor



Railway Technology



Monitoring & Control

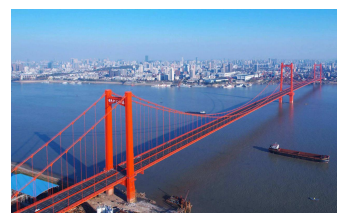

Structure Health Monitor

Super Reliability & Performance

www.SkyMEMS.com Mobile: +86 133 7203 8516
Skype: skymems

Copy Right Reserved © 2019 Nanjing Sky MEMS Technology co., Ltd.
Focus on MEMS Measurement & Control Technologies, Products include:

MEMS Acc	MEMS Gyro	IMU	Vertical Gyro	AHRS
INS	GNSS/INS	E-compass	Inclinometer	FOG

MAS3012

High Performance Triaxial MEMS Accelerometer Sensor

Technical Specifications

Technical Specs		
Type	MS3012	Remarks
Axis Number	3	
Range	±2g	
Zero Bias	±20mV	
Scale Factor Sensitivity (Differential Output)	1800±20mV/g	
Bandwidth (-3dB)	≥1000Hz	
Output Noise	1.0µg/√Hz	
Non-linearity	0.1%F.R	
Cross-axes Influence	3%	
Bias Temperature Coefficient	±0.2mg/°C	
Scale Factor Temperature Coefficient	120ppm/°C	
Output Voltage (Differential Output)	0~ ±3.6V OutP :0.5~4.5V OutN: 0.5~4.5V	OutP, OutN full range output
Self Test Function		
Frequency	19Hz	Square wave output
Duty Ratio	50%	
Amplitude	0.8g	Peak value
Triaxial Self Test Threshold Voltage	4Vmin 5Vmax	High level is valid
Electrical Specs		
Working Voltage	7~40V or 5V±3%	
Working Current	≤25mA	Three axes
Startup Time	20ms	
Environment Performance		
Operating Temperature	-40~+85°C	
Storage Temperature	-55~+125°C	
Shock Resistance	6000g	
Physical Specs		
Dimensions	37×30×25mm	
Casing	aluminum alloy	
Weight	30grams (without lines)	76 grams (with lines)

MAS3012

High Performance Triaxial MEMS Accelerometer Sensor

Pins Definition

Pins Definition of Differential Output Interface

No.	Line color	Definition	Function
1	Red	VCC	Power Input (7~40V or 5V±3%)
2	Black	GND	GND
3	Blue	X_OUTP	X axis output
4	Green	X_OUTN	
5	Purple	Y_OUTP	Y axis output
6	Grey	Y_OUTN	
7	Yellow	Z_OUTP	Z axis output
8	Brown	Z_OUTN	
9	White	ST	self test input (high level power is valid, input 5V)

Dimensions

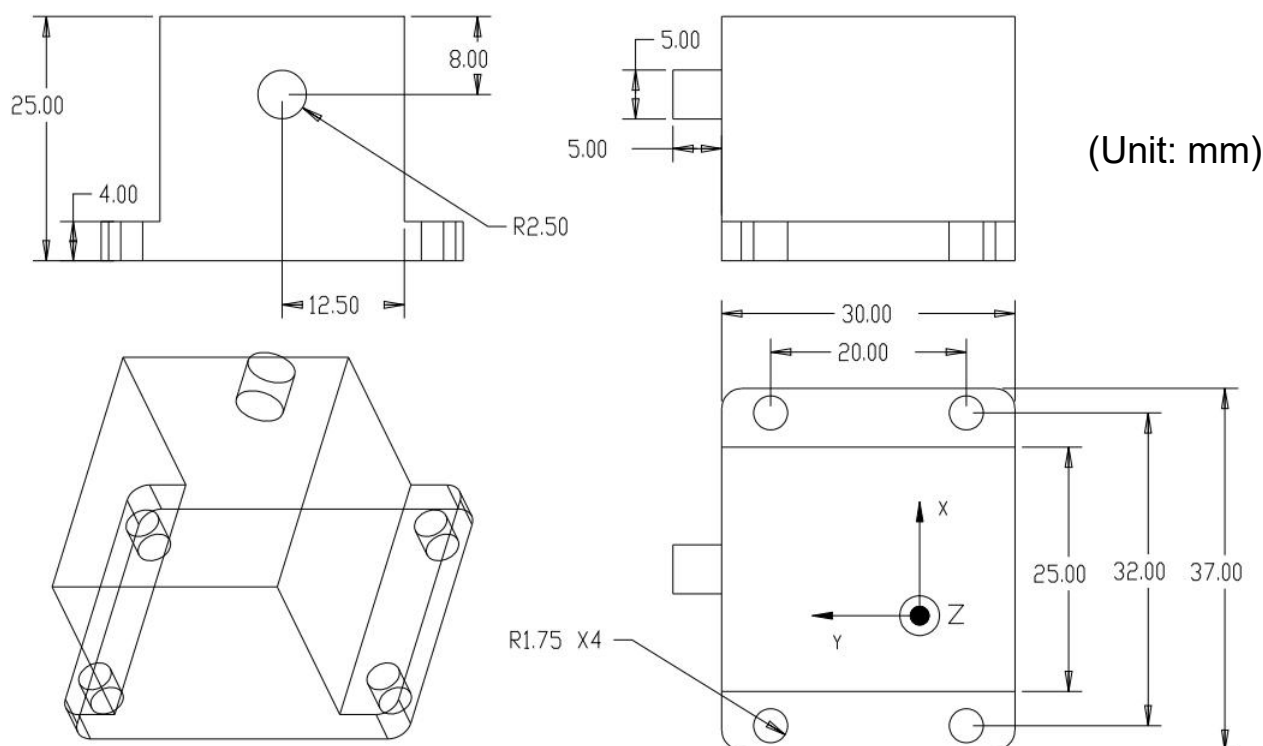

Super Reliability & Performance

MAS3012

High Performance Triaxial MEMS Accelerometer Sensor

Principle of Self Test

MS3012 has self test function, it can measure the working status of accelerometer in three axes, when built-in self test mode, the square wave signal output will be generated, which can be used to malfunction test.

When it is activated, coil will generate alternating static power mechanical sensing element and it will simulate a frequency that define an input acceleration. static power is used to the sensor's self test except the inertial acceleration, so it is recommended to do the self test function in static conditions.

Cautions

Use Restrictions	
Maximum working voltage	40V or 5.15V
Proximity effect	The accelerometer is very sensitive to the surrounding capacitance, if the object is very close (mm level) to the accelerometer, this may influence the accelerometer's performance. In order to get good performance, the distance between the accelerometer and other objects should be more than 1cm, or the surface that close to the accelerometer is GND.
ESD caution 	ESD (electrostatic discharge) sensitive device. Charged devices and circuit boards can discharge without detection. Although this product features patented or proprietary protection circuitry, damage may occur on devices subjected to high energy ESD. Therefore, proper ESD precautions should be taken to avoid performance degradation or loss of functionality.

Absolute Max. Ratings

Absolute Maximum Ratings	
Parameter	Rating Value
Vcc	-0.2V~+40V or +5.15V
ST	5V
Working Temperature	-40~+85°C
Storage Temperature	-55~+125°C

Remarks: the accelerometer that works long time in absolute maximum ratings may influence the reliability.

MAS3012

High Performance Triaxial MEMS Accelerometer Sensor

Order Information



Product Model: MS3012

XX: Measurement Range:

02 = ± 2g

X: Axis Numbr

T = 3 Axes

X: power supply

H = 7~40V

L = 5v±3%

X: Output mode

D = differential output

X: line lengh, X means

length, normally 1 meter

XXXX: bandwidth

NC: default bandwidth

0200 = 200Hz

For example, MS3012-02-T-L-D-015-1000 means that ± 2g range, 3 axes, 5V±3% power supply, 0.15meter length line, 1000Hz bandwidth accelerometer sensor